

H02C Magnetlås 600 kg

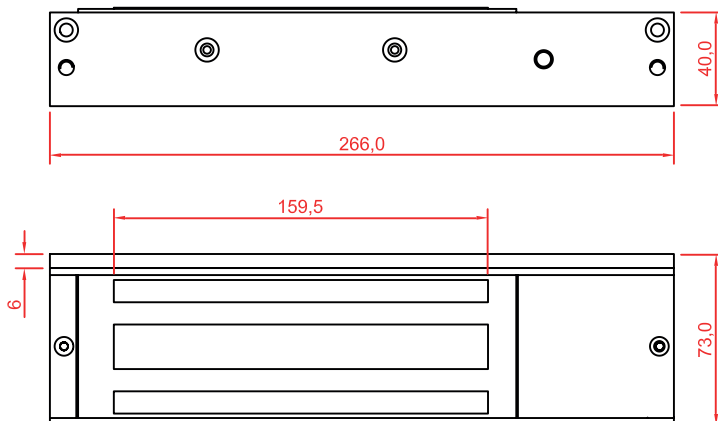

H02



H02 elektromagnetisk lås

H02 er en utenpåliggende magnetlås for innvendig bruk med holdekraft på 600 kg. Hall effect sensor gir låst/ulåst status som vises via LED. Innebygget overspenningsbeskyttelse. Driftsspenning valgbar 12V eller 24V DC. Monteringsbraketter bestilles separat.

Vedlikehold

Kontroller 1 - 2 ganger pr år, eller oftere ved behov, at produktet fungerer tilfredstillende. Rengjøres med en fuktig klut. Trekk til eventuelle løse festeskruer. Dokumenter og utbedre eventuelle skader.

Egenskaper

Holdekraft:	600 kg, 2500 N
Driftsspenning:	12V / 24V DC
Strømforbruk:	500 mA / 250 mA
Materiale:	Alu. legering
Mål i mm bxhxd:	266x73x40



Typisk installasjon

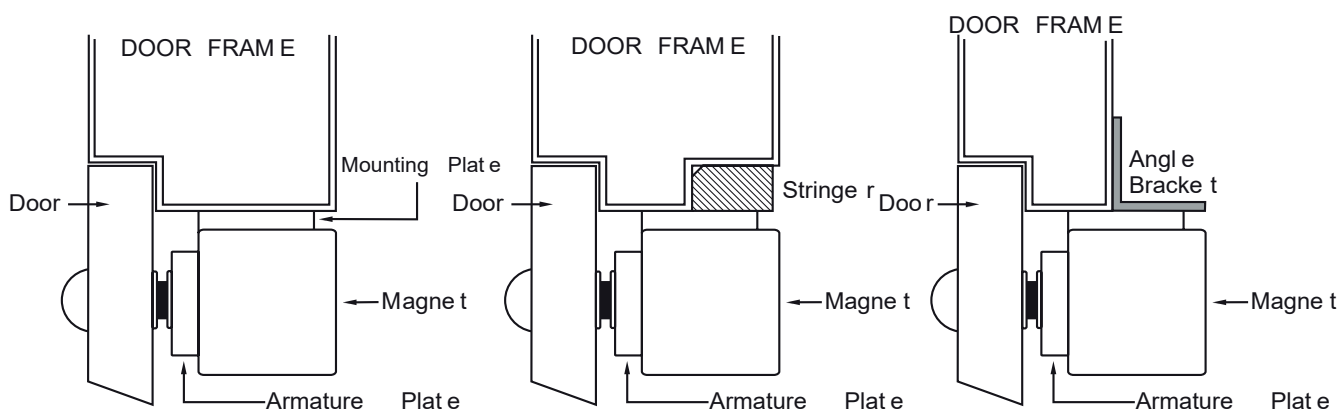

Varenr

234H02C030	MAGNETLÅS H02, 600KG, SENSOR, LED, 12/24 VDC, 250mA/24V	
234B1002030	MONTERINGSBRACKETT B1002, L&Z, MAGNETLÅS H02	(se tegning side 2)
234B0001030	MONTERINGSPLATE B0001 FOR ANKER MAGNETLÅS H02	(se tegning side 2)

Monteringsbraketter for H02C

B1002 L & Z monteringsbrakett for magnetlås H02C

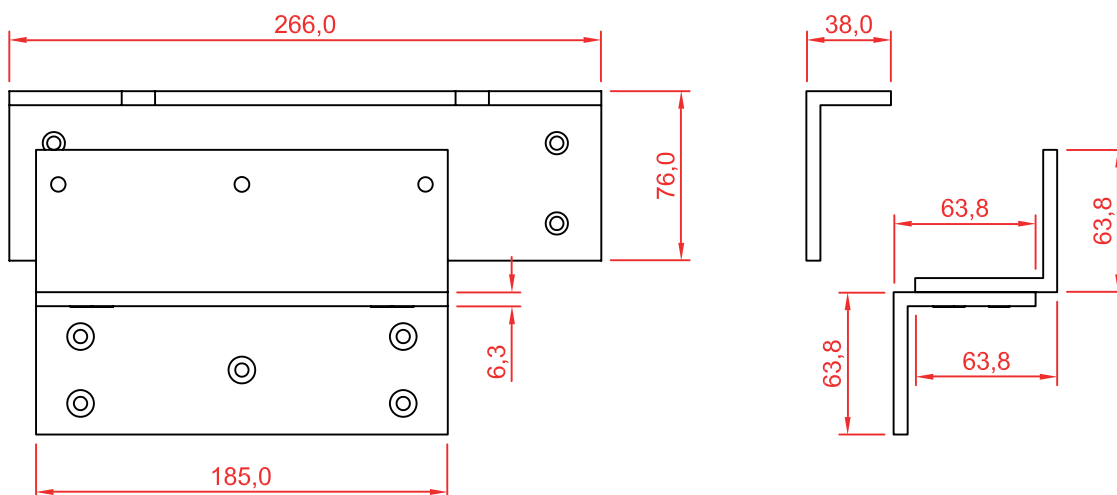

B0001 Monteringsbrakett for ankerplate til magnetlås H01C

